

ET-SS TERMINAL

REVISION REGISTER

Issue & Revision	Description	Date
1	Issued for use.	25/03/2020
1 A	TL2 Configuration accepted. Baseplated configuration accepted for TL2. Post anchor foundation accepted.	13/01/2022

The ET-SS Terminal is a single-sided, energy absorbing, redirective and gating end terminal. When hit end on the W-Beam guardrail is flattened as it is guided through the impact head connected to the front anchor (Post #0), this absorbs impact energy from the vehicle bringing it to a controlled stop.

Note that the ET2000+ terminal was previously accepted by Main Roads but is no longer be accepted for new installations.

Photograph and Drawings:



Photograph of Terminal

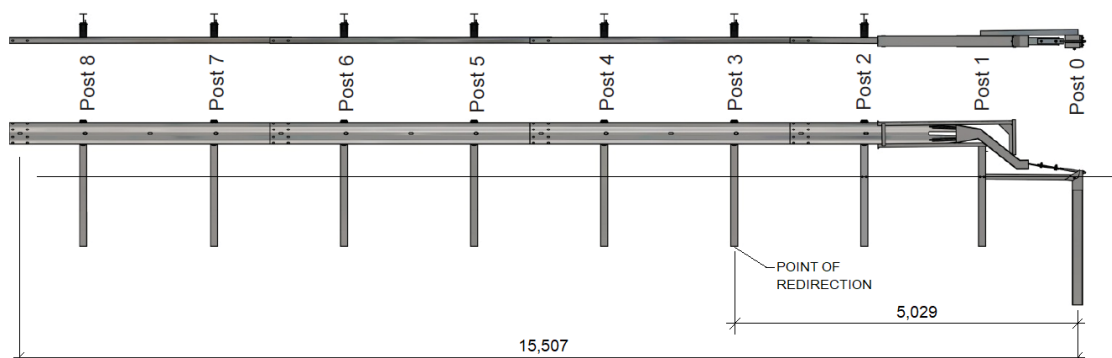

Plan and Elevation View (TL3 Configuration)

ET-SS TERMINAL

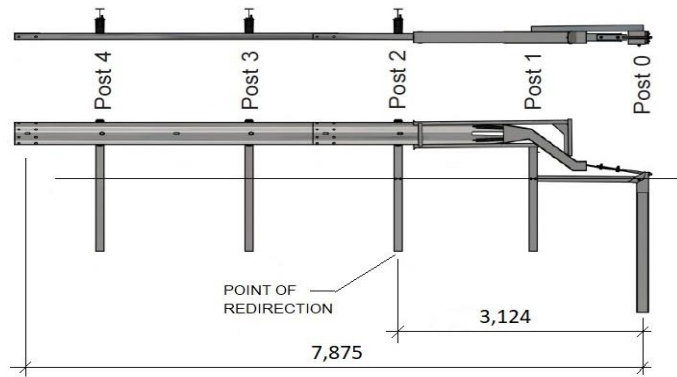

Plan and Elevation View (TL2 Configuration)

Ownership: Trinity Industries Inc. USA
www.highwayguardrail.com

Supplier: Ingal Civil Products
 3 Temperley Close, Welshpool WA 6106
 Ph: (08) 08 9358 9139
 Website - <http://www.ingalcivil.com.au/>

Test Level: Tested in accordance with MASH TL2 and TL3.

TL	Length (m)	Design Speed (km/hr)	Point of Redirection – Leading (m)	Point of Redirection - Trailing (m)	Suppliers Drawing
2	7.785*	70km/hr	3.124**	3.124**	SS-STD- 012
3	15.507*	100km/hr	5.029**	5.029**	SS-STD- 001

*.. Taken from Post #0 to W-Beam splice.

** Point of redirection is at post #2 for TL2 configuration and at post #3 for TL3 configuration.

Configuration:

- Post 1 and Post 2 are steel yielding terminal posts (SYTP).
- The sticker on the impact head which is 480 mm x 130 mm is to be Black bands on White Class 1 reflective backgrounds with the width marker pattern as shown in Australian Standard 1742.2 Sign D4-3 (L,R).
- System shall be supplied with Offset King Block blockouts.

Design:

- Design to be in accordance with the ET-SS Product Manual Release 08/21, which can be found on the Ingal website.
- Preferred plan layout is to install the end treatment at the recommended flare of 25:1 to reduce nuisance impacts.
- In locations of constrained width or on high embankments where the cost to provide additional width is not warranted then the terminal may be installed parallel to the road.
- Refer to Main Roads Drawings 201531-0096 and 201531-0097 for grading requirements around the ET-SS.

ET-SS TERMINAL

- As part of the design, the Designer shall check to ensure that there are no site constraints such as rock, cover to services or pipes or other factors that would preclude the use of the normal post lengths.
- Terminal has been crash tested when installed in AASHTO standard soil (i.e. CBR \geq 60). Refer to supplier for installation in other soil conditions.
- When the ET-SS is installed on the departure end of a barrier system the terminal is to be oriented as per Sketch 1.

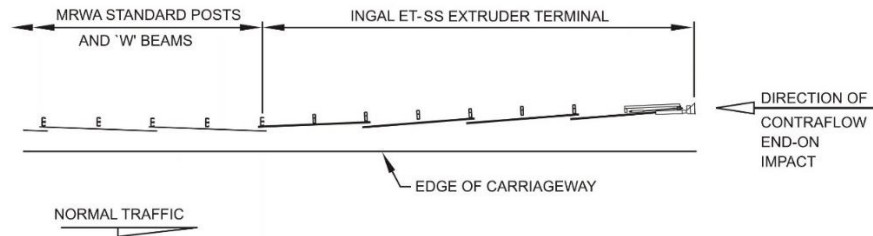

- Departure end terminal guardrail to be lapped against the normal traffic flow as shown.
- Post associated with the end treatment are to be orientated for an end-on impact on the extruder head, that is, against the normal traffic flow.

Sketch 1: Departure End Treatment Layout

(Based on SES 01/03)

Limitations:

- Must be installed on a straight flare or parallel to the travel way.
- An alternative anchor post foundation has been developed for Post 0, as per Supplier's drawing SS-STD-010. This treatment should be limited to constrained locations where a driven post cannot be installed. A site specific ground investigation must be undertaken for this treatment. As this treatment may increase maintenance and repair costs, approval from the MRWA asset owner is required prior to implementation.
- An alternative configuration where all posts of the TL2 configuration are connected via baseplates to a continuous concrete slab has been developed, as per Supplier's drawing SS-STD-011. This treatment should be limited to constrained locations where driven posts cannot be installed. As this treatment may increase maintenance and repair costs, approval from the MRWA asset owner is required prior to implementation.

Installation and Maintenance Requirements:

- The end treatment shall be installed and repaired after impact in accordance with the installation instructions that can be found in the ET-SS Product Manual Release 08/21.
- If an ET2000+ terminal is impacted then the complete terminal should be replaced with an ET-SS.

References:

Relevant FHWA Approval Letters:

Refer to website:

http://safety.fhwa.dot.gov/fourthlevel/hardware/term_cush.htm

Code	Description
CC-115G	MASH TL3