

DB80 T150S CONCRETE SAFETY BARRIER - TEMPORARY

REVISION REGISTER

Revision	Description	Date
1	Issued for use.	25/10/2022

DB80 T150S is a freestanding temporary concrete barrier (2, 4 and 6 metre units) that must be anchored at each end. DB80 T150S consists of Type F shape steel reinforced concrete barrier units with a tension bar coupling system and without intermediate ground attachment.

DB80 K150 is a freestanding temporary concrete barrier, which has a different joint system. It is approved for use by Main Roads WA, with conditions under a separate design sheet.

Drawings:

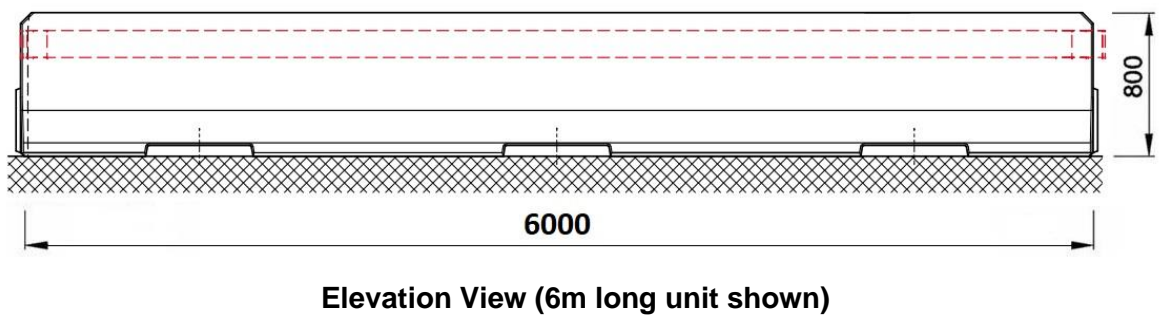
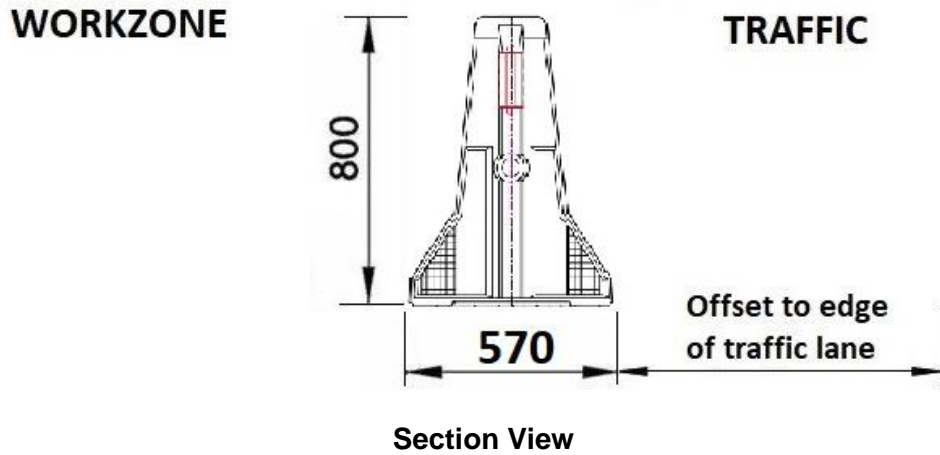

DB80 T150S CONCRETE SAFETY BARRIER - TEMPORARY



Photograph of DB80 T150S Units

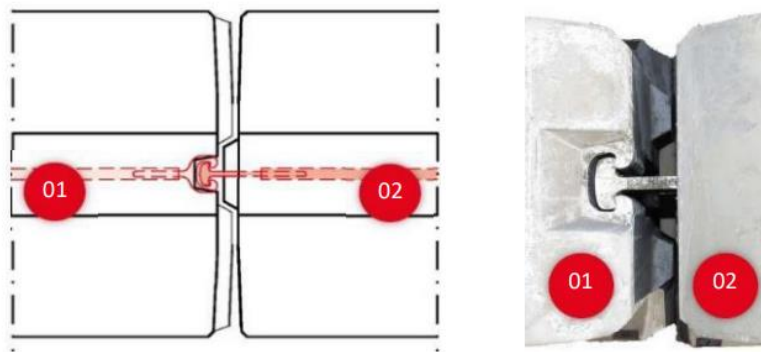

Images of DB80 T150S Joints

Ownership:

Delta Bloc International GmbH

Supplier:

Orange Equipment:

13 Penelope Crescent, Arndell Park, NSW 2148.

Ph 1800 769 121

<https://www.orangehire.com.au/>

Test Level: Crash tested to MASH TL 3 and MASH TL 4.

Test Level	Test Description	Deflection	Working Width
MASH – TL 3	2270 kg vehicle at 100km/h 25° impact angle	0.81 m	1.36 m
MASH – TL 4	10000 kg vehicle at 90km/h 15° impact angle	0.81 m	2.50 m

Note that while the DB80 T150S Concrete Safety Barrier has passed crash testing to MASH TL 3 and TL 4, the barrier system when connected to approved terminals is not accepted at 100km/h.

DB80 T150S CONCRETE SAFETY BARRIER - TEMPORARY

Configuration:

- Units must be interconnected using patented couplings and requires a sufficient length to resist impact.

Design Considerations:

- Design to be in accordance with the DB 80 F-Shape 6m T150S Product Manual (Australia) – Rev V1.8, dated 1 November 2021.
- The barrier is designed to resist loadings by deflection, so the units should be free to move. The barrier shall not be placed onto a mortar or a concrete blinding as this may overload the connections between the units.
- It is recommended that the barrier should as a minimum be offset from the edge of traffic lane by:
 - traffic speed 40 km/h or less - 0.2 m;
 - traffic speed 41 to 60 km/h - 0.3 m;
 - traffic speed 61 to 80 km/h - 0.5m.
- Barrier length must be sufficient to protect the hazard.
- Kerbing is not to be placed in front of the barrier.
- Kerbing should not be placed behind the barrier within the deflection limits of the system.
- Barrier shall not be placed on top of kerbing as this negates the effects of the profile.
- The approach to the barrier should be a trafficable running surface at a slope of 10% or flatter clear of objects and grade changes to allow an errant vehicle to hit the barrier at an appropriate height.
- When designing a DB80 T150S barrier the flare rates used shall be those for a rigid barrier, to minimise impact angles.

Minimum Length:

92 m excluding terminals.

Terminals permitted:

1. TAU-M crash cushion

- The installation is restricted to a posted speed of 80 km/h or less.
- May only be installed where reverse impacts are highly improbable and a risk assessment has been completed and steps undertaken to mitigate any risks identified.
- Terminal must be anchored by pins in accordance with the installation instructions in the product manual.
- The DB80 T150S barrier units adjacent to the crash cushion must be anchored to the pavement as required by the product manual.
- An accepted transition must be used to connect the terminal to the barrier.

2. Quadguard M10 CZ crash cushion

- The installation is restricted to a posted speed of 80 km/h or less.
- May only be installed where reverse impacts are highly improbable and a risk assessment has been completed and steps undertaken to mitigate any risks identified.
- Terminal must be anchored by pins in accordance with the installation instructions in the product manual.
- The DB80 T150S barrier units adjacent to the crash cushion must be anchored to the pavement as required by the product manual.
- An accepted transition must be used to connect the terminal to the barrier.

DB80 T150S CONCRETE SAFETY BARRIER - TEMPORARY

Point of Redirection:

The point of redirection for MASH TL 3 conditions shall be the interface between the barrier and the end treatment.

The point of redirection for MASH TL 4 conditions shall be 32.8 m from the leading end of the DB80 T150S barrier and 59.7 m from the trailing end of the DB80 T150S barrier.

Limitations:

- The use of DB80 T150S barrier is limited to work site situations and units shall be interconnected using the patented coupling.
- Objects should not be placed on top of the barrier as they are designed to move under impact. "Gawk" screens are not acceptable.
- The minimum radius that the DB80 T150S barrier can be installed on is 52 m using 2 m units, 103 m using 4 m units, and 135 m using the 6 m units. The use of 2 m units is restricted to tight radius curves and emergency openings.

Installation and Maintenance Requirements:

In accordance with the DB 80 F-Shape 6m T150S Product Manual (Australia) – Rev V1.8, dated 1 November 2021.

Parts to be Replaced after Impact:

Units may need to be repaired after impact or replaced depending on the extent of damage.

Parts Typically Re-Useable after Impact:

Undamaged units.

References:

Refer to Main Roads file 19/1578.