



mainroads  
WESTERN AUSTRALIA

*We're working for  
Western Australia.*

# Operating Conditions

Containerised Cargo

(import/export)

Period Permit

Printed copies are uncontrolled unless marked otherwise.  
Refer to the Main Roads Website for current version.

D20#547012  
May 2021

# Contents

<b>DEFINITIONS .....</b>	<b>4</b>
<b>1 APPLICATION .....</b>	<b>5</b>
1.1 Approved Vehicles .....	5
1.2 Approved Product .....	5
1.3 Approved Axle Configuration .....	6
1.4 Operating in Conjunction with another Permit or Order .....	6
<b>2 USING A NON-COMPLYING VEHICLE .....</b>	<b>6</b>
2.1 Obtaining Exemptions or Modifications .....	6
2.2 Accepted Non-Complying Vehicles .....	6
<b>3 DIMENSION REQUIREMENTS .....</b>	<b>7</b>
3.1 Length Limits .....	7
3.2 Axle Spacings .....	7
<b>4 MASS REQUIREMENTS .....</b>	<b>8</b>
4.1 General Requirements .....	8
4.2 Maximum Gross Mass .....	8
4.3 Maximum Axle Group Mass .....	8
4.4 Steer Axle Mass Limits .....	8
<b>5 ACCESS REQUIREMENTS .....</b>	<b>9</b>
5.1 Approved Roads and Conditions .....	9
5.2 Speed Restrictions .....	9
<b>6 COMPULSORY HEAVY VEHICLE INCIDENT REPORTING .....</b>	<b>9</b>
<b>7 AMENDMENTS TO OPERATING CONDITONS &amp; ACCESS .....</b>	<b>9</b>
7.1 Access Approval Suspension & Revocation .....	9
7.2 Amendments & Notifications .....	9

# Document Control

<b>Owner</b>	Main Roads Heavy Vehicle Services
<b>Custodian</b>	Manager Heavy Vehicle Road Network Access
<b>Document Number</b>	D20#547012
<b>Issue Date</b>	4 May 2021
<b>Review Frequency</b>	As required.

# Amendments

Revision Number	Revision Date	Description of Key Changes	Section / Page No.
1	08/09/2020	Updated Compulsory Heavy Vehicle Incident Reporting.	6 / 9
2	04/05/2021	Note added to section 5.1.2 regarding further expansion of the Import/ Export Containerised Cargo Networks.	9

## DEFINITIONS

The following are definitions for terms used in these Operating Conditions. Refer to the definitions in the *Road Traffic (Administration) Act 2008* and the *Road Traffic (Vehicles) Act 2012* and any subsidiary legislation to these Acts for the meanings of any terms not defined in this section. If a definition in the relevant Acts or the subsidiary legislation conflicts with a definition in this section, the definition in this section prevails for the purpose of these Operating Conditions.

Term	Definition
<b>Intermodal Container</b>	A shipping container designed and built for intermodal freight transport.
<b>Main Roads Website</b>	<a href="http://www.mainroads.wa.gov.au">www.mainroads.wa.gov.au</a>
<b>Permit</b>	Means a permit issued under Part 4 of the <i>Road Traffic (Vehicles) Act 2012</i> , which these Operating Conditions form part of.
<b>Permit Holder</b>	The Operator to whom the permit is issued.
<b>Prime Mover</b>	A motor vehicle built primarily to tow a semi-trailer, but does not include a truck or modified prime mover built primarily to carry a load or carry out a function other than towing a semi-trailer.
<b>RAV</b>	An approved vehicle combination to which the “ <i>Containerised Cargo (import/export) Period Permit</i> ” applies.
<b>Import / Export Containerised Cargo Network 1</b>	The Import / Export Containerised Cargo Network 1 approved roads are published in the form of Road Tables or are available on the RAV Mapping Tool on the Main Roads website.
<b>Import / Export Containerised Cargo Network 2</b>	The Import / Export Containerised Cargo Network 2 approved roads are published in the form of Road Tables or are available on the RAV Mapping Tool on the Main Roads website.
<b>Import / Export Containerised Cargo Network 3</b>	The Import / Export Containerised Cargo Network 3 approved roads are published in the form of Road Tables or are available on the RAV Mapping Tool on the Main Roads website.
<b>Import / Export Containerised Cargo Network 4</b>	The Import / Export Containerised Cargo Network 4 approved roads are published in the form of Road Tables or are available on the RAV Mapping Tool on the Main Roads website.
<b>Statutory Mass Limits</b>	The mass limits prescribed in Part 8 of the <i>Road Traffic (Vehicles) Regulations 2014</i> .

# 1 APPLICATION

## 1.1 Approved Vehicles

1.1.1 The *Containerised Cargo (import/export) Period Permit* applies to a RAV in the following table when carrying the approved product:

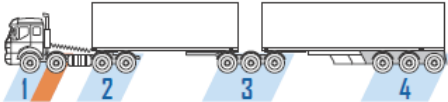
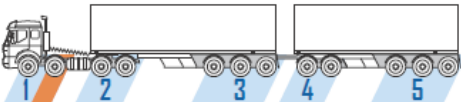
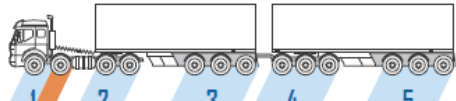
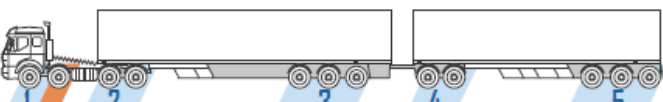
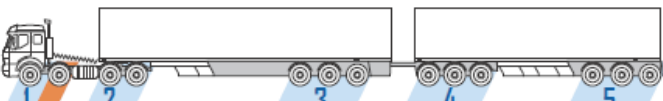
Category 1 RAV				
Category	Vehicle Description	Length	Max. Mass	Approved Network
1.1	Prime Mover & Semi Trailer 	≤19.0 m	57 t	Import / Export Containerised Cargo Network 1
Category 2 RAV				
Category	Vehicle Description	Length	Max. Mass	Approved Network
2.1	B-Double 	≤27.5 m	77 t	Import / Export Containerised Cargo Network 2
Category 3 RAVs				
Category	Vehicle Description	Length	Max. Mass	Approved Network
3.1	A-Double (Prime Mover, Semi Trailer & 5 Axle Dog Trailer) 	≤27.5 m	93.5 t	Import / Export Containerised Cargo Network 3
3.2	A-Double (Prime Mover, Semi Trailer & 6 Axle Dog Trailer) 	≤27.5 m	93.5 t	Import / Export Containerised Cargo Network 3
Category 4 RAVs				
Category	Vehicle Description	Length	Max. Mass	Approved Network
4.1	A-Double (Prime Mover, Semi Trailer & 5 Axle Dog Trailer) 	>27.5 m ≤36.5 m	93.5 t	Import / Export Containerised Cargo Network 4
4.2	A-Double (Prime Mover, Semi Trailer & 6 Axle Dog Trailer) 	>27.5 m ≤36.5 m	93.5 t	Import / Export Containerised Cargo Network 4

1.1.2 All axle groups of the RAV, except the steer axles, must be fitted with dual tyres.

## 1.2 Approved Product

1.2.1 The *Containerised Cargo (import/export) Period Permit* only applies to a RAV when carrying intermodal container(s) that have been imported or are being exported overseas.

- 1.2.2** For the purpose of sub-clause 1.2.1, this includes containers being transported to and from the port and any intermediate movements to locations such as intermodal terminals and container parks, provided the container contents are not altered, i.e. the import / export container seal remains intact.
- 1.2.3** This permit does not apply to intermodal containers that are being transported for any other purpose.

### 1.3 Approved Axle Configuration

- 1.3.1** The axle groups of a RAV described in Clause 1.1 are colour coded to indicate the minimum and maximum number of axles allowable for that category of vehicle, as shown below:



- 1.3.2** The *Containerised Cargo (import/export) Period Permit* does not apply to a RAV with less than the number of axles indicated.
- 1.3.3** The *Containerised Cargo (import/export) Period Permit* does not apply to a RAV with more than the number of axles indicated.

### 1.4 Operating in Conjunction with another Permit or Order

The *Containerised Cargo (import/export) Period Permit* cannot be used in conjunction with another permit or order.

## 2 USING A NON-COMPLYING VEHICLE

### 2.1 Obtaining Exemptions or Modifications

A RAV may consist of a non-complying vehicle mentioned in Clause 2.2, provided the relevant licensing authority has issued the necessary vehicle standards exemption or dimension modification.

### 2.2 Accepted Non-Complying Vehicles

- 2.2.1** A semi-trailer with a non-complying length may be used, provided:
- (a) The semi-trailer does not exceed 14.63 metres in length; and
  - (b) The semi-trailer does not exceed 9.5 metres from the king pin to the centre of rear axle group; and
  - (c) The semi-trailer does not exceed 13.2 metres from the king pin to the rear of the trailer; and
  - (d) The front of the semi-trailer forward of the king pin does not exceed 1.43 metres or a radius of 1.9 metres; and
  - (e) The semi-trailer is used as the rearmost trailer in the vehicle combination.
- 2.2.2** A semi-trailer with a non-complying tow coupling underrun may be used, provided:
- (a) The distance from the rearmost part of the semi-trailer or load, to the forward most part of the following semi-trailer or load, is not less than 1270 millimetres; or
  - (b) Specific approval is obtained from Main Roads Heavy Vehicle Services.

**2.2.3** A dolly with a non-complying drawbar height may be used, provided:

- (a) The drawbar is level when the combination is parked on level ground. For the purpose of this sub-clause, level means no more than 100 millimetres height difference between the drawbar ends; or
- (b) The drawbar is a gooseneck drawbar.

**2.2.4** A dolly with a drawbar that exceeds the maximum prescribed length may be used, provided:

- (a) The dolly has a gooseneck drawbar; and
- (b) The front of the drawbar is connected more than 300 millimetres forward of the rear of the leading trailer.

### 3 DIMENSION REQUIREMENTS

#### 3.1 Length Limits

**3.1.1** A RAV must not exceed the maximum length indicated for the particular vehicle category in Clause 1.1.

**3.1.2** The two (2) semi-trailers used in a B-double must not be more than 22 metres in combined length, measured from the front of the lead semi-trailer to the rear of the second semi-trailer (including the space between the semi-trailers and excluding any rounded front or attachments to the front of the lead trailer).

#### 3.2 Axle Spacings

**3.2.1** A RAV must comply with the minimum axle spacing requirements specified in the following table:

**Table A**

Adjacent axles or axle groups	Minimum distance
Tandem axle group to tri axle group	8.0 m
Tri axle group to tri axle group	9.2 m

**3.2.2** Despite sub-clause 3.2.1, a Category 3.1 RAV may comply with the minimum axle spacing requirements specified in the following table:

**Table B**

Adjacent axles or axle groups	Minimum distance
Tandem axle group to tri axle group	6.9 m

Axle spacing measurements are taken from the outmost extreme axles of the two adjacent axle groups, as shown below:

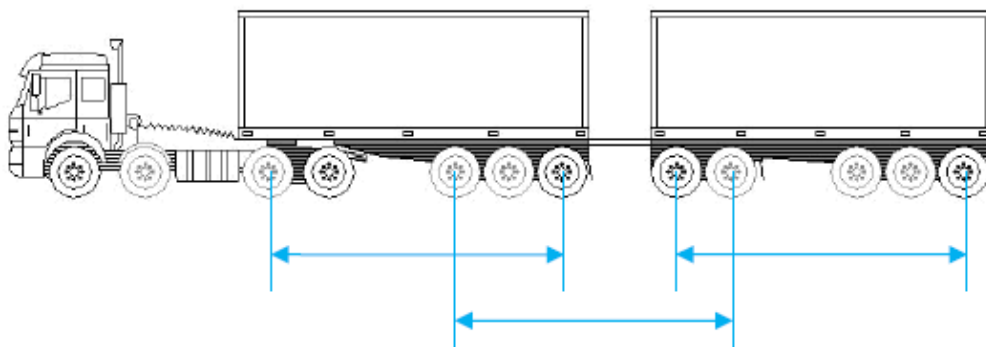

“Single Axle” does not include a single steer axle.

“Tandem axle group” does not include a twin steer axle group.

## 4 MASS REQUIREMENTS

### 4.1 General Requirements

4.1.1 The modified mass limits specified in Section 4 only apply to a RAV carrying one (1) intermodal container per trailer.

4.1.2 Where a modified mass limit has not been specified, statutory mass limits apply.

### 4.2 Maximum Gross Mass

4.2.1 A RAV must not exceed the maximum mass indicated for the particular RAV category in Clause 1.1.

### 4.3 Maximum Axle Group Mass

4.3.1 A Category 1 RAV must not exceed the axle group mass limits specified in the following table:

Axle Group	Mass Limit
Tandem Drive Axle Group	18 t
Semi-trailer Tri Axle Group	27 t

4.3.2 A Category 2, 3 and 4 RAV must not exceed the axle group mass limits specified in the following table:

Axle Group	Mass Limit
Tandem Drive Axle Group	18 t
Lead Semi-trailer Tri Axle Group	27 t

4.3.3 Alternatively, to sub-clause 4.3.2, a Category 2, 3.1 and 4.1 RAV must not exceed the axle group mass limits specified in the following table:

Axle Group	Mass Limit
Tandem Drive Axle Group	17 t
Semi-trailer Tri Axle Groups	23.5 t
Tandem Dolly Axle Group	17 t

### 4.4 Steer Axle Mass Limits

4.4.1 The steer axles on a RAV must not exceed a mass limit specified in the following table:

Axle Group	Mass Limit
Single Steer Axle with tyres <375 mm	6.5 t
Single Steer Axle with tyres ≥375 mm	7 t
Twin Steer Axle Group with non-load sharing suspension	10 t
Twin Steer Axle Group with load sharing suspension and tyres <375 mm	11 t
Twin Steer Axle Group with load sharing suspension and tyres ≥375 mm	12 t

**Note:** The maximum mass indicated in Clause 1.1 is based on a twin steer axle with 12 tonnes.



## 5 ACCESS REQUIREMENTS

### 5.1 Approved Roads and Conditions

- 5.1.1 A RAV must not operate on any road that is not in the Approved Network specified for the particular vehicle category in Clause 1.1.
- 5.1.2 A RAV must operate in accordance with any conditions specified for a particular road in the Approved Network.

\*Note: There will be no further expansion of the Import/ Export Containerised Cargo Networks.

### 5.2 Speed Restrictions

Unless otherwise specified as a condition for a particular road in the Approved Network, a RAV must not travel at a speed exceeding 10 km/h lower than the posted speed limit, where the posted speed limit is greater than 60 km/h.

## 6 COMPULSORY HEAVY VEHICLE INCIDENT REPORTING

All on-road incidents involving a RAV must be reported to Main Roads Heavy Vehicle Services by the permit holder. The Heavy Vehicle Incident Reporting form is available on the Incident Reporting page on the Main Roads website and it must be submitted within 48 hours of the incident occurring.

## 7 AMENDMENTS TO OPERATING CONDITIONS & ACCESS

### 7.1 Access Approval Suspension & Revocation

- 7.1.1 Approval to operate a RAV may be suspended when road and/or traffic conditions are considered unsuitable. Main Roads personnel, WA Police or Traffic Escort Wardens, may make verbal notification of such suspension.
- 7.1.2 Approval to operate a RAV may be suspended or revoked if the operator or vehicle combination fails to comply with any of the requirements specified in these Operating Conditions.

### 7.2 Amendments & Notifications

- 7.2.1 These Operating Conditions are subject to occasional amendments. If amendments are made that impact transport operators, they will be published as an "HVS Update" on the Main Roads website on the first working day of the month. Operators and drivers are required to ensure that they are operating vehicles on the public road network in accordance with the current and up to date Operating Conditions.
- 7.2.2 The RAV Networks are subject to periodic amendments, which include additional roads being included in the lists, roads being removed from the lists, or amendments being made to a condition relating to a particular road in the lists. RAV Network updates will be effective from the Wednesday following the amendment and the RAV Networks are maintained on the Main Roads website. Operators and drivers are required to ensure they are operating vehicles on the public road network in accordance with the current and up to date RAV Networks.
- 7.2.3 Heavy Vehicle Travel Impacts are published when road conditions may impede the movement of Restricted Access Vehicles. Operators and drivers are required to check the Heavy Vehicle Travel Impacts page on the Main Roads website prior to operating the vehicle on the public road network to ensure that there is no relevant information that will impede their vehicle operating on the WA road network.
- 7.2.4 All conditions stipulated in HVS Updates or Heavy Vehicle Travel Impacts must be adhered to.