

RAMSHIELD STEEL RAIL BARRIER

REVISION REGISTER

| Revision | Description | Date |
|----------|--|------------|
| 1 | Issued for use. | 10/11/2016 |
| 1 A | Rail height increased, terminals updated, 1m post spacing and 6m clear span configurations added. Acceptance conditions updated. | 17/03/2022 |
| 1 B | Max-Tension terminal added. | 17/12/2024 |
| 1 C | Median and Low Deflection variants added. Base plate, 6 m clear span and 1 m post spacing configurations amended. | 19/06/2026 |

RAMSHIELD is a semi-rigid steel rail barrier system which is accepted for use by Main Roads.

Identification Photographs:



Front View



Rear View

Drawings:

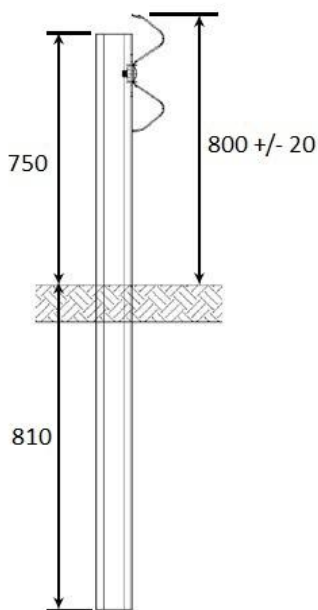

Typical Cross Section

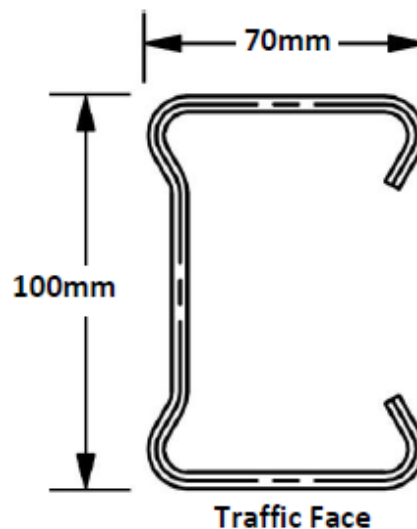

RAMSHIELD Post Section

RAMSHIELD STEEL RAIL BARRIER

Ownership: Safe Direction Pty Ltd

Supplier: Safe Direction Pty Ltd
Unit 2, 5 Simpson Close, Smeaton Grange, NSW 2567
Ph: (02) 4648 0394
Website - <http://www.safedirection.com.au/>

Test Level:
MASH TL 3 (i.e. 2270 kg vehicle).

Configuration:
The RAMSHIELD steel rail barrier consists of W-beam rail, which is attached to RAMSHIELD posts at 2000 mm centres. The system does not have blockouts, but a release tab is incorporated into the post to control the release of the rail from the posts during impacts.

The RAMSHIELD Posts are 1560 mm long and driven into the ground so that the height of the top of post is 750 mm above ground. The top of the W-beam rail is at a height 800 mm above ground.

Unless stated in this document the installation shall be in accordance with the RAMSHIELD Product & Installation Manual (Version 020/04) available on the Safe Direction Pty Ltd website.

Design Considerations:

Test Deflection:
1.56 m under MASH TL 3 conditions (2270 kg vehicle at 100 km/hr at 25° impact angle)

Note that this deflection was measured in a crash test performed under controlled conditions. The deflection measured is the horizontal offset between the face of the W-beam rail measured prior to and following vehicle impact. Designers should be aware that the deflection figure published as a test result may not be the deflection value achieved in the field for all impacts by errant vehicles.

For other speeds refer to Supplier.

Working Width:
1.63 m under MASH TL 3 conditions (2,270 kg vehicle at 100 km/h and 25°)

Minimum Length:
The minimum length of RAMSHIELD barrier is 66 m (full terminal lengths not included). That is, the minimum length does not include the length of public domain W-beam required for transition to end treatments.

Offset from Kerbing:
As the RAMSHIELD barrier does not include a blockout, a greater offset than public domain W-beam is required. The face of RAMSHIELD barrier is to be placed 300mm from the face of the kerb to minimise nuisance impacts and allow driving of posts to be clear of the kerb.

Locations offset further from the kerb are not preferred because of the possibility of vehicle either vaulting the barrier or not being redirected by the barrier.

RAMSHIELD STEEL RAIL BARRIER

Approach to barrier:

The approach to the barrier should be a trafficable running surface at a slope of 1 in 10 or flatter clear of objects and grade changes to allow an errant vehicle to hit the barrier at an appropriate height.

End Treatments:

MSKT, Max-Tension and public domain W-beam terminals. Refer to RAMSHIELD Product & Installation Manual (Version 020/04).

Limitations:

- The RAMSHIELD barrier is a proprietary system that is designed as a “weak” post system, so its installation is restricted to soils equivalent to an AASHTO weak soil or stronger (i.e. $CBR \geq 8$).
- When installed in embankment conditions in soils equivalent to AASHTO weak soil or stronger (i.e. $CBR \geq 8$) the hinge point shall be offset a minimum of 0.8 m from the rear of RAMSHIELD barrier post (refer to figure below).
- When installed in embankment conditions in soils equivalent to AASHTO standard soil or stronger (i.e. $CBR \geq 60$) the hinge point shall be offset a minimum of 0.5 m from the rear of RAMSHIELD barrier post (refer to figure below).

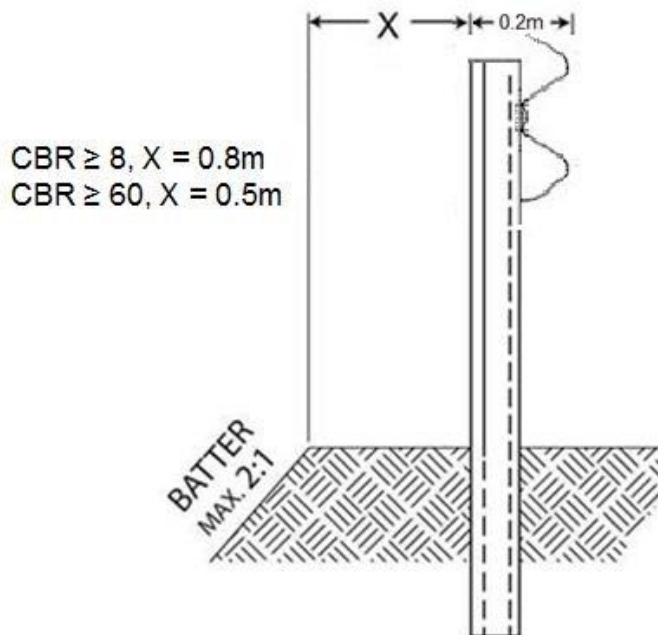

Offset from hinge point

- The RAMSHIELD barrier configuration using posts on base plates is available. For this configuration the concrete footing must be designed to suit the ground conditions, and this treatment must be at least 12 m long. This detail is only intended for use in constrained situations, such as avoiding clashes between posts and existing underground services. Approval is required from MRWA Road & Traffic Engineering Branch prior to specifying this configuration.
- The RAMSHIELD barrier configuration of back to back W-beam attached to a single line of posts is available (i.e. RAMSHIELD Median). However, approval is required from MRWA Road & Traffic Engineering Branch prior to specifying this configuration.

RAMSHIELD STEEL RAIL BARRIER

- The RAMSHIELD Low Deflection variant is available. However, approval is required from MRWA Road & Traffic Engineering Branch prior to specifying this variant.
- The RAMSHIELD barrier configuration utilising a 6 m long clear span is available (Refer to drawing GR-WB-095). For this configuration the offset to the hinge point must be at least the same as the dynamic deflection (1.56 m). This detail is only intended for use in constrained situations, such as avoiding clashes between posts and existing underground services. Approval is required from MRWA Road & Traffic Engineering Branch prior to specifying this configuration.
- The RAMSHIELD barrier configuration using posts at 1 m spacing (and a reduced deflection) is available. This detail is only intended for use in constrained situations and may reduce performance of the barrier. Approval is required from MRWA Road & Traffic Engineering Branch prior to specifying this configuration.
- Should not be installed behind kerbs if possible. If kerbing is required, then the accepted kerbing is mountable Type A 100 mm. Semi-mountable and barrier kerbing shall not be used in front of barrier. Refer to Main Roads Standard Drawing 9331-0376 for kerb types.
- If installed behind a mountable kerb, the top of the W-beam rail height shall be measured from the top of kerb.
- RAMSHIELD barrier is not to be used for repairs of damaged sections of public domain W-beam barrier system.

References:

| Item | Description |
|------|--|
| 1 | System tested on December 8 and December 10, 2014 by Holmes Solution to MASH TL 3. A copy of this testing can be found on Main Roads file 15/4810. |
| 2 | Hinge point test conducted on February 11, 2015 by Holmes Solution. A copy of this testing can be found on Main Roads file 15/4810. |

Relevant FHWA Approval Letters:

https://safety.fhwa.dot.gov/roadway_dept/countermeasures/reduce_crash_severity/barriers/pdf/b319.pdf

Drawings:

Refer to Safe Direction drawing GR-WB-060 for assembly details.

References:

RAMSHIELD Product & Installation Manual (Version 020/04)

Refer to website: <https://www.safedirection.com.au/>

Refer to Main Roads WA file 15/4810.