

BG800 MDS (MINIMUM DEFLECTION SYSTEM)

REVISION REGISTER

Revision	Description	Date
1	Issued for use.	13/05/2016.
1 A	Product Name changed. Owner / Supplier details updated. Product Manual reference updated. Barrier offsets amended.	11/03/2020
1 B	Updated conditions, terminals and manual.	9/08/2021
1 C	Updated conditions, terminals and manual.	14/10/2022
1 D	Absorb-M terminal clarified, NCHRP 350 rated terminals removed, pavement types updated and use of radius sections clarified.	10/04/2026

BG800 is a portable steel barrier, which is anchored to the pavement at the ends (and at intermediate anchors at 60 m spacing) and is considered a semi rigid system. It is approved for use by Main Roads WA, with conditions under a separate design sheet.

BG800 MDS (Minimum Deflection System) is a variant of BG800, with anchors at 6 m spacing, an additional steel section (referred to as the "T-Top") fitted to the top of the barriers and reduced deflections. At the beginning and end of a length of BG800 MDS a ramped transition piece is installed to shield the exposed ends of the T-Top.

The BG800 MDS is also considered a semi rigid system that is approved for use in temporary applications.

BG800 MDS may be considered for permanent installation. However, approval is required from MRWA Road & Traffic Engineering Branch prior to specifying this application.

Images:

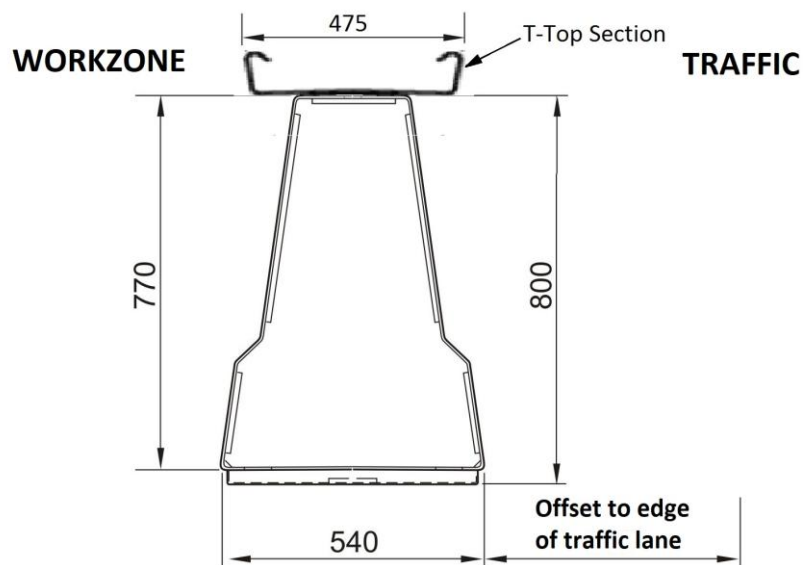

Typical Cross Section

BG800 MDS (MINIMUM DEFLECTION SYSTEM)



Photograph (showing T-Top section)

Ownership:

Ownership
Highway Care 3 Bullace Lane, Dartford, Kent DA1 1BB, United Kingdom
Supplier
Ingal Civil Products 3 Temperley Close, Welshpool 6106 Ph: (08) 9358 9139 http://www.ingalcivil.com.au/home

Test Level: Approved to NCHRP 350 TL 3.

Test Level	Test Description	Deflection	Working Width (measured at base)
MASH – TL3	2,270 kg vehicle @ 100 km/h, 25° impact angle	0.44 m	0.98 m

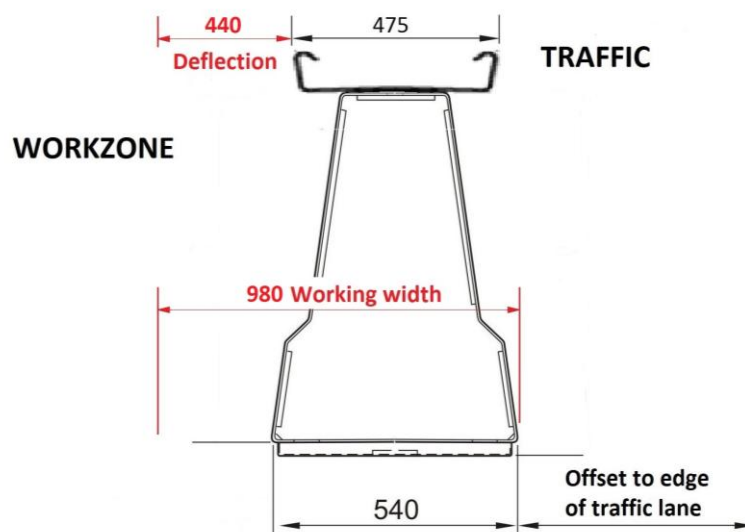

Deflection and Working Width shown in Cross Section

BG800 MDS (MINIMUM DEFLECTION SYSTEM)

Configuration:

As the barrier is designed to resist loadings by deflecting, the units should be free to move but the system must be anchored at each end and at intermediate locations. Units must be anchored with chemically set threaded rods.

The location of pinned intermediate anchors shall be at intervals not greater than 6 m.

Design Considerations:

- Design to be in accordance with BG800 Product and Installation Manual IMP-031 Issue 1.2, dated 20 August 2021.
- It is recommended that the barrier should be offset from the edge of traffic lane by:
 - traffic speed 40 km/h or less – 0.2 m,
 - traffic speed 41 to 60 km/h – 0.3 m,
 - traffic speed 61 to 80 km/h – 0.5 m,
 - traffic speed greater than 80 km/h – 1.0 m.
- Barrier length must be sufficient to adequately protect the hazard.
- Where the ends of the barrier may be impacted, they should be protected with a terminal that is permitted.

Minimum Length:

42 m (including anchor points) for a MASH TL 3 impact.

Note that BG800 MDS may be used within a longer length of BG800, with the transition pieces for the T-Top sections. In this situation a minimum length of 42 m of BG800 MDS must be installed.

Point of Redirection:

The leading and trailing points of redirection shall be the interface between the barrier and end treatment.

Terminals Permitted:

- Absorb-M (suitable for maximum design speed = 70 km/h, maximum posted speed = 60 km/h)
- SMART crash cushion.
- TAU-M crash cushion.
- Quadguard M10 CZ crash cushion.

Crash cushions may only be installed where reverse impacts are highly improbable and a risk assessment has been completed and steps undertaken to mitigate any risks identified.

Note that at the beginning and end of a length of BG800 MDS a Full Height Terminal is required. Where a crashworthy terminal is required, a crash cushion is attached to the Full Height Terminal.

BG800 MDS (MINIMUM DEFLECTION SYSTEM)

The following terminals are no longer accepted.

- Absorb 350
- Tau-II crash cushion
- Quadguard crash cushion (including CZ version)

Connections Permitted:

BG800 MDS may be used within a longer length of BG800, with transition pieces for the T-Top sections.

BG800 MDS may be connected to permanent concrete barrier, with transition pieces for the T-Top sections and a nested Thrie beam connection as detailed by the Supplier.

Limitations:

- The cross slope shall be not greater than 10% for the area between the edge of travelled way and the barrier, and the area immediately behind the barrier for the width of the deflection.
- Cannot be placed adjacent to kerbs or other objects within the deflection limits of the barrier, which may prevent lateral displacement.
- Not to be used on longitudinal slopes or crossfalls greater than 8%.
- To be used where pavement consists of:
 - 200 mm thick reinforced or unreinforced concrete,
 - 100 mm thick asphalt over 150 mm basecourse,
 - 250 mm thick asphalt.

For pavements not meeting these requirements design advice shall be sought from the Supplier.

- Anchoring details consist of:
 - 250 mm long epoxied M24 threaded rod (for concrete pavement)
 - 450 mm long epoxied M24 threaded rod (for asphalt pavement)
- The use of 5° and 10° radius sections is restricted to tight radius curves and emergency openings. Where 5° and 10° radius sections are used the speed should be restricted to a design speed of 60 km/h or less (posted at 50 km/h or less) – Refer Austroads Technical Advice SBTA-23-002.
- This product is designed for constrained sites ONLY that cannot accommodate the working widths of more flexible systems. While providing lower working width, this product increases the potential for vehicle occupant risk during high-speed impacts.
- Throughout the installation it is recommended to revert to greater pin spacing (LDS, Standard) where there is the accepted working width behind the installation.
- A risk assessment for using this product must be undertaken. Where the risk of high-speed is high, the design speed must be limited to no greater than 80 km/h.
- Objects should not be placed on top of the barrier as they are designed to move under impact. “Anti-Gawk” screens are not to be attached.

Installation and Maintenance Requirements:

In accordance with the Product Manual. The holes for the anchors made to accommodate the anchor pins must be repaired.

BG800 MDS (MINIMUM DEFLECTION SYSTEM)

Parts to be Replaced after Impact:

Units may need to be repaired after impact or replaced depending on the extent of damage.

Parts Typically Re-Useable after Impact:

Undamaged units.

References:

BG800 Product and Installation Manual IMP-031 Issue 1.2, dated 20 August 2021.

Item	Description
1	Barrier system information can be found on Main Roads file 12/5468.