



mainroads
WESTERN AUSTRALIA

*We're working for
Western Australia.*

Guidelines

Measuring the Dimensions of an Oversize Vehicle

Printed copies are uncontrolled unless marked
otherwise. Refer to iRoads for current version.

D20#926442
March 2021

Contents

| | |
|--|-----------|
| DEFINITIONS | 3 |
| REFERENCES AND RELATED DOCUMENTS | 4 |
| 1 PURPOSE | 5 |
| 2 WHAT ARE DIMENSION REQUIREMENTS | 5 |
| 3 WHAT IS A MEASUREMENT ADJUSTMENT | 5 |
| 4 WIDTH | 6 |
| 4.1 Assessment Method | 6 |
| 4.2 Measurement Adjustment | 6 |
| 5 LENGTH | 7 |
| 5.1 Assessment Method | 7 |
| 5.2 Measurement Adjustment | 7 |
| 6 HEIGHT | 7 |
| 6.1 Assessment Method | 7 |
| 6.2 Measurement Adjustment | 8 |
| 7 REAR OVERHANG | 8 |
| 7.1 Assessment Method | 8 |
| 7.2 Measurement Adjustment | 8 |
| 8 FORWARD PROJECTION | 9 |
| 8.1 Assessment Method | 9 |
| 8.2 Measurement Adjustment | 9 |
| 9 REAR PROJECTION | 9 |
| 9.1 Assessment Method | 9 |
| 9.2 Measurement Adjustment | 10 |
| 10 GROUND CLEARANCE | 10 |
| 10.1 Assessment Method | 10 |
| 10.2 Measurement Adjustment | 10 |
| 11 GROUND CONTACT WIDTH | 10 |
| 11.1 Assessment Method | 10 |
| 11.2 Measurement Adjustment | 10 |
| 12 AXLE SPACINGS | 11 |
| 12.1 Assessment Method | 11 |
| 12.2 Measurement Adjustment | 11 |
| 13 APPENDICES | 13 |
| Appendix 1 – Low Loader Overmass Period Permit Axle Spacing Ranges | 14 |
| Appendix 2 – Platform Trailer Relocation Period Permit Axle Spacing Ranges | 17 |
| Appendix 3 – Single Trip Permit Prime Mover Axle Spacing Range | 18 |

Document Control

| | |
|-------------------------|-------------------------------|
| Owner | Heavy Vehicle Permits Manager |
| Custodian | Senior Traffic Escort Warden |
| Document Number | D20#926442 |
| Issue Date | 18/03/2021 |
| Review Frequency | Annually or as required |

Amendments

| Revision Number | Revision Date | Description of Key Changes | Section / Page No. |
|-----------------|---------------|----------------------------|--------------------|
| | | | |
| | | | |
| | | | |
| | | | |

DEFINITIONS

| Term | Definition |
|----------------------------------|--|
| OSV | Oversize Vehicle means a vehicle that exceeds a statutory dimension limit, including its load. |
| Permit | A permit issued under Part 4 of the Road Traffic (Vehicles) Act 2012. |
| Projection | The distance an object extends beyond the normal confines or body of the vehicle to the front, side or rear. |
| Rear Overhang Line | The centre of a single axle, single axle group, tandem axle group, tri axle group or quad axle group nearest to the rear of the vehicle. |
| Rear Overhang | Of a vehicle, means the distance between the rear overhang line and the rearmost part of the vehicle or the load. |
| Statutory Dimension Limit | A dimension limit prescribed in Part 8 of the <i>Road Traffic (Vehicles) Regulations 2014</i> . |
| TEW | A Main Roads Traffic Escort Warden. |

REFERENCES AND RELATED DOCUMENTS

| Document Number | Description |
|-----------------------|---|
| D19#696602 | Single Trip Oversize Vehicle – Standard Operating Conditions. |
| D13#399261 | Low Loader Overmass Period Permit Operating Conditions. |
| D19#752785 | Platform Trailer Relocation Period Permit Operating Conditions. |
| D20#835117 | Traffic Escort Warden Job Paperwork. |
| Legislation WA | Road Traffic (Vehicles) Regulations 2014. |

1 PURPOSE

This document outlines the process that should be followed when measuring the dimensions of an OSV.

2 WHAT ARE DIMENSION REQUIREMENTS

Dimension requirements include the **maximum** dimension limits, **minimum** dimension limits, **actual** dimensions and an allowable dimension **range** that apply to a vehicle and its load. The dimension requirements are specified in the particular permit applying to the OSV.

With reference to an OSV permit, the maximum dimension limits include:

- Height
- Length
- Width
- Rear overhang
- Rear projection
- Forward projection
- Ground clearance
- Raised Height

Minimum Dimension limits include:

- Ground contact width
- Ground clearance raised
- Lowered Height

Actual Dimensions include:

- Axle spacing's (applicable to Single Trip Permit and Bridge Crossing Permit)

A dimension range includes:

- An axle spacing range approved under a Period Permit, such as the Low Loader Overmass Period Permit or Platform Trailer Relocation Period Permit. The axle spacing range sets both the minimum and maximum dimension limit.

3 WHAT IS A MEASUREMENT ADJUSTMENT

A measurement adjustment is a tolerance that is applied when a vehicle is measured for compliance purposes.

A measurement adjustment recognises that there may be inaccuracies in the measurements due to:

- The measuring equipment used;
- The inspection site characteristics;
- Measuring methods; and
- The conditions under which the measurements are taken.

Measurement adjustments should be applied for each step that the measurement is taken in. As such, wherever possible, measurements should be taken in a single step. However, if a one-step

measurement cannot be achieved, it is acceptable to take the measurement of an OSV using multiple steps.

Example - Step 1. Measure the total width of the deck of the OSV. Step 2. Measure the width of the OSV from the deck to the widest point on the left hand side of the OSV. Step 3. Measure the width of the OSV from the deck to the right hand side of the OSV.

This is known as a 3-step measurement, add the 3 measurements together to calculate the total width of the OSV.

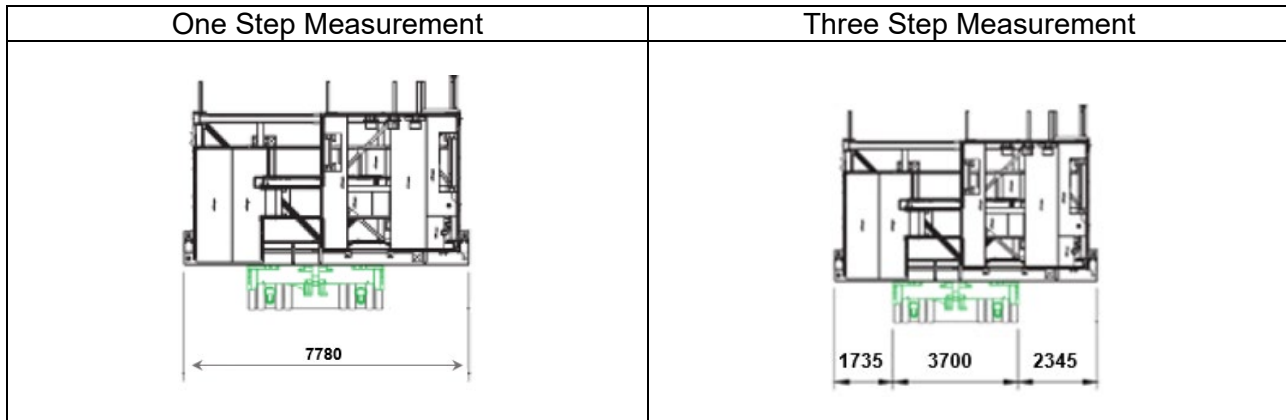

Note: If the tape measure cannot be attached at the exact point required for the measurement, however can be attached to a point nearby, the measurement between these two points to determine the final measurement does not need to be counted as a measurement step.

4 WIDTH

The width of an OSV is the measurement taken at the widest point on each side of the OSV.

4.1 Assessment Method

When measuring the overall width of an OSV, a TEW will use their issued verified tape measure (60.0m or 8.0m) to measure the load at its widest points. Care must be taken to ensure that all extremities of the load are taken into account. Wherever possible, the end of the tape measure should be attached to one side of the OSV, at the widest point and then extend the tape measure out to the widest point on the opposite side of the OSV and record the measurement, this is known as a one-step measurement.

Where the tape measure cannot be attached to one side of the OSV, assistance will be required from another person to hold the end of the tape measure. Where the widest point is at a height that is out of reach, a third person may be required to assist with sighting when the tape measure aligns with the widest points.

4.2 Measurement Adjustment

If the width measurement exceeds the width limit specified on the permit, a **20 mm measurement adjustment** shall be applied and recorded for each step taken when measuring the width of an OSV.

Example – If the width of an OSV has been measured in 3 steps, then a **60 mm** measurement adjustment shall be applied and recorded.

5 LENGTH

When measuring the overall length of an OSV, the measurement must be taken from the forward most point of the OSV to the most rear point of the OSV, including any rear projection or loading ramps.

5.1 Assessment Method

Attach the issued verified 60.0m tape measure to the front or rear of the OSV and extend the tape measure the full length of the OSV. A measuring wheel may be used, however if the measurement taken varies from the length specified on the Permit by more than 1 metre, a measurement must be taken using the issued verified 60.0 metre tape measure. (Note - measuring wheels are to be used for length measurements only).

Request assistance from another person if there is difficulty in taking the overall length measurement. Alternatively, place the 60.0 metre tape measure on the ground alongside the OSV (use a counter weight to hold the tape measure in place) and record the measurement.

5.2 Measurement Adjustment

If the length measurement exceeds the length limit specified on the permit, the following measurement adjustments are applicable dependant on the overall length of the OSV:

- OSV **up to 27.5 metres** in length, a measurement adjustment of **100 mm** shall be applied.
- OSV **greater than 27.5 metres** in length, a measurement adjustment of **300 mm** shall be applied.

Wherever possible, OSV length measurements are to be taken in a single step. However, where more than one-step is required to measure the length of an OSV, measurement adjustment must be applied by the number of times you take a measurement to establish the overall length. The measurement must be taken in the minimum number of steps possible and in a manner requiring the minimum measurement to be applied.

Example – If an OSV is measured at 70 metres in overall length and it has taken 2 steps, the first step should be taken using the entire length of the tape measure, i.e. 60 metres and the second step measuring the remainder of the OSV to determine the overall length. As such, a measurement adjustment of **400 mm** shall be applied.

Measuring the OSV in two equal measurements, i.e. 35 metres and 35 metres, resulting in a 600 mm measurement adjustment being applied, is not appropriate, unless there is no alternative.

6 HEIGHT

The height of an OSV is the measurement taken from the ground to the highest point of the OSV including ancillary items such as rotating beacons and whip aerials.

Where a raised height and a lowered height are specified on the permit, the height measurement should be taken when the vehicle is in both the raised height and lowered height positions.

6.1 Assessment Method

When measuring the overall height of an OSV, a TEW will use their issued height stick to measure the load at its highest point. Care must be taken to ensure that the highest part of load is taken into account, which may not be in an obvious position. Wherever possible, the end of the height stick should be attached to the top of the highest point of the load.

Where the height stick cannot be attached to the highest point of the load, assistance will be required from another person to assist with sighting when the height stick aligns with the highest point.

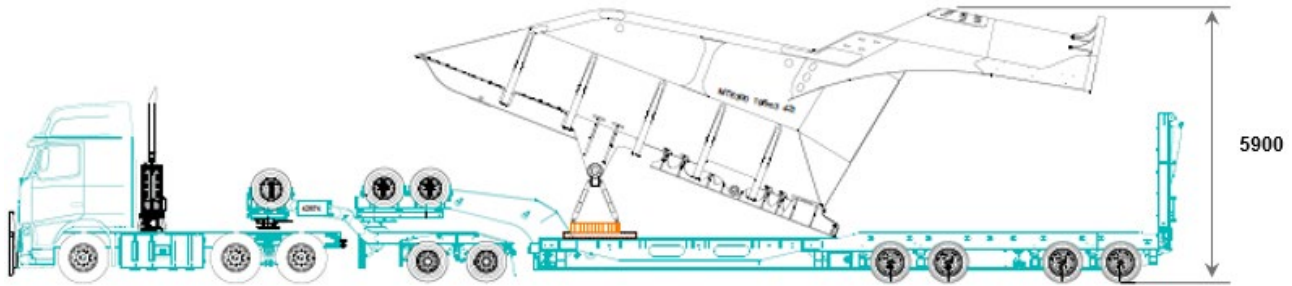

6.2 Measurement Adjustment

If the height measurement exceeds the height limits specified on the permit, **no measurement adjustment** shall be applied. Due to a minimal safety clearance of 300 mm being applied to overhead structure assessments, there is considerable risk of damage to overhead structures if a measurement adjustment is applied. As such, a permit amendment will be required.

Note: Where the OSV is being escorted under the supervision of a cable operator, the measurement taken by the cable operator will be deemed to be the overall height of the OSV.

7 REAR OVERHANG

The rear overhang of an OSV is the measurement taken from the rear overhang line to the rear most part of the OSV, such as the ramps or the rear projecting load. Rear overhang does not apply to a platform trailer.

7.1 Assessment Method

When measuring the rear overhang of an OSV, a TEW will use their issued verified tape measure (60.0m or 8.0m). Wherever possible, the end of the tape measure should be attached to the trailer adjacent to the rear overhang line and then extend the tape measure out to the rearmost part of the OSV, or conversely, attach the tape measure to the rearmost part of the load and extend the tape measure out to the rear overhang line.

Where the tape measure cannot be attached to the trailer or load, assistance will be required from another person to hold the end of the tape measure in the correct position.

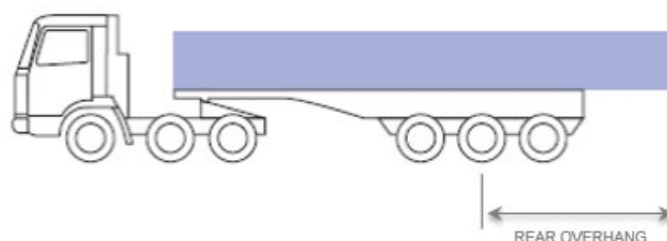

7.2 Measurement Adjustment

If the rear overhang measurement exceeds the rear overhang specified on the permit, a **50mm measurement adjustment** shall be applied and recorded.

8 FORWARD PROJECTION

The forward projection of an OSV is the measurement from the point of articulation (kingpin) of the trailer to the forward most part of the load.

8.1 Assessment Method

When measuring the forward projection of an OSV, a TEW will use their issued verified tape measure (60.0m or 8.0m). Wherever possible, the end of the tape measure should be attached to the trailer adjacent to point of articulation and then extend the tape measure out to the forward most part of the load, or conversely, attach the tape measure to the forward most part of the load and extend the tape measure out to the point of articulation.

Where the tape measure cannot be attached to the trailer or load, assistance will be required from another person to hold the end of the tape measure in the correct position.

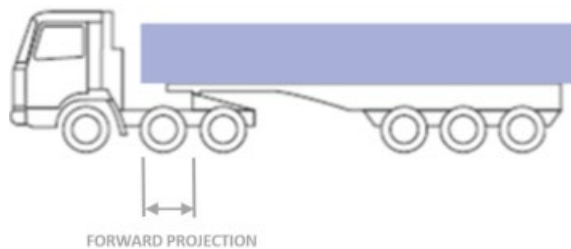

8.2 Measurement Adjustment

If the forward projection measurement exceeds the forward projection limit specified on the permit, a **50 mm measurement adjustment** shall be applied and recorded.

9 REAR PROJECTION

The rear projection of an OSV is the measurement from the rear of the trailer to the rear of the load.

9.1 Assessment Method

When measuring the rear projection of an OSV, a TEW will use their issued verified tape measure (60.0m or 8.0m). Wherever possible, the end of the tape measure should be attached to the rear of the trailer and then extend the tape measure out to the rearmost part of the load, or conversely, attach the tape measure to the rearmost part of the load and extend the tape measure out to the rear of the trailer.

Where the tape measure cannot be attached to the trailer or load, assistance will be required from another person to hold the end of the tape measure in the correct position.

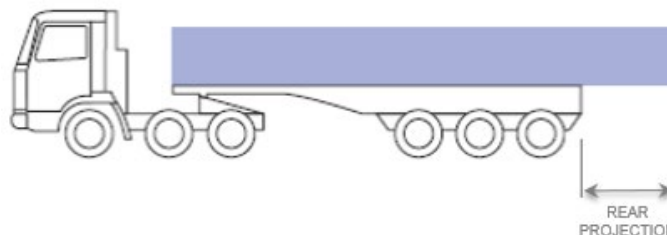

9.2 Measurement Adjustment

If the rear projection measurement exceeds the rear projection limit specified on the permit, a **50mm measurement adjustment** shall be applied and recorded.

10 GROUND CLEARANCE

The ground clearance of an OSV is the measurement from the lowest point of the load to the ground. Where a raised ground clearance requirement is also specified on the permit the height measurement should be taken when the vehicle is in both the raised and lowered positions.

10.1 Assessment Method

When measuring the ground clearance of an OSV, a TEW will use their issued verified 8.0 metre tape measure. Care must be taken to ensure that the measurement is taken between the lowest point of the load and the ground.

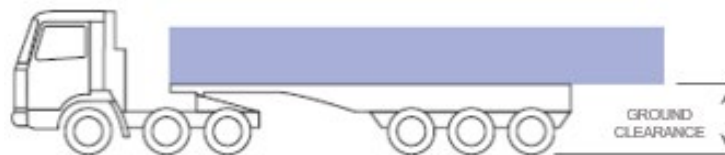

10.2 Measurement Adjustment

If the ground clearance measurement is less than the ground clearance requirement specified on the permit, a **50mm measurement adjustment** shall be applied and recorded.

11 GROUND CONTACT WIDTH

The Ground Contact Width (GCW) is the measurement between the outermost point of ground contact of the outside tyres on each end of the axle. GCW must not be confused with the spread of the deck of the low loader or pin hole measurements marked on the low loader. The GCW specified on the permit is the minimum requirement.

GCW may be applicable to a low loader and/or a low loader dolly where specified.



11.1 Assessment Method

When measuring the GCW of an OSV, a TEW will use their issued verified tape measure (60.0m or 8.0m). Attach the end of the tape measure onto the outermost edge of the outer tyre, in contact with the ground, at the end of one axle. Extend the tape measure out to the outermost edge of the outer tyre, in contact with the ground, at the opposite end of the axle and record the measurement.

11.2 Measurement Adjustment

If the GCW measurement is less than the GCW requirement specified on the permit, a **50 mm measurement adjustment** shall be applied and recorded.

12 AXLE SPACINGS

Axle spacing measurements are critical measurements, which are used as part of the assessment process to determine if an OSV is able to access the road network without causing damage to road infrastructure, in particular drive over structures.

Axle spacing's are measured between adjacent axles. The axle spacing measurement of the OSV must comply with the **actual** axle spacing requirements or be within the axle spacing **range** specified within the permit or permit operating conditions.

The different axle spacing **ranges** are shown in Appendix 1 to 3.

12.1 Assessment Method

When measuring the axle spacing's of an OSV, a TEW will use their issued verified tape measure (60.0m or 8.0m). It is best practice to commence the measurements from the steer axle of the prime mover and methodically measure the axle spacing's from the front of the combination to the rear.



Axle spacing measurements are to be taken from the centre of the axle to the centre of the adjacent axle. Alternatively, axle spacing measurements can be taken from the outside of the rim to the same position on the outside of the rim on the adjacent axle.

Refer below diagrams illustrating the two acceptable methods of measuring axle spacing's.

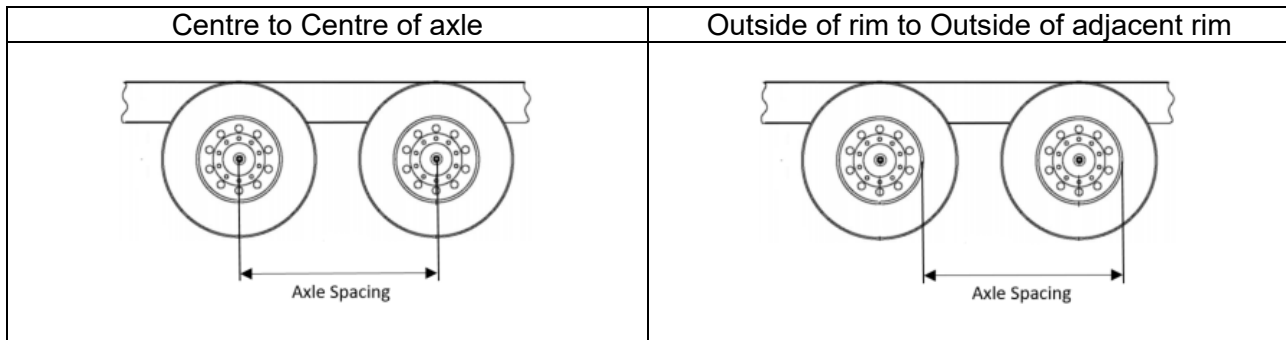

12.2 Measurement Adjustment

If the axle spacing measurement is not the same as the **actual** axle spacing requirement specified on the permit or within the axle spacing **range** applicable to the permit, a **50 mm measurement adjustment** shall be applied and recorded, except for the axle spacing between prime mover to dolly / trailer and dolly to trailer axle group (refer below). Where the axle spacing measurement exceeds the specified axle spacing, the 50 mm measurement adjustment shall be deducted from the measurement. Where the axle spacing measurement is less than the specified axle spacing, the 50 mm measurement adjustment shall be added to the measurement.

Where the vehicle combination consists of a **Prime Mover and trailer only (no dolly)**, a **300 mm measurement adjustment** shall be applied and recorded. Where the axle spacing measurement exceeds the specified axle spacing, the 300 mm measurement adjustment shall be deducted from

the measurement. Where the axle spacing measurement is less than the specified axle spacing, the 300 mm measurement adjustment shall be added to the measurement.

Where the vehicle combination consists of a prime mover, dolly and trailer, a measurement adjustment of up to 300 mm between the prime mover and dolly or dolly and trailer may be applied, provided the overall measurement adjustment between the rear drive axle and front trailer axle does not exceed 450 mm.

Example of compliant measurement adjustment

- Red** - Single Trip Permit specified axle spacing.
- Blue** - Actual recorded axle spacing using a verified tape measure.

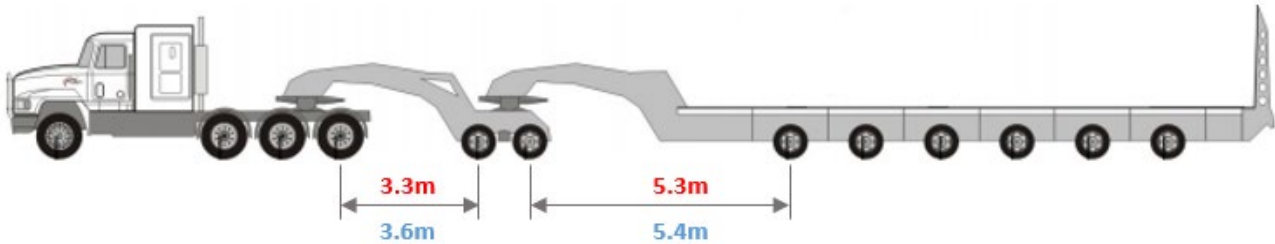

Prime mover to dolly axle spacing is compliant as measurement adjustment between 3.3m and 3.6m equals maximum allowable measurement adjustment of 300mm.

Dolly to trailer axle spacing is compliant as measurement adjustment between 5.3m and 5.4m is 100mm and does not exceed 450mm when added to measurement adjustment for prime mover and dolly.

Example of non-compliant measurement adjustment

- Red** - Single Trip Permit specified axle spacing.
- Blue** - Actual measured axle spacing using a verified tape measure.

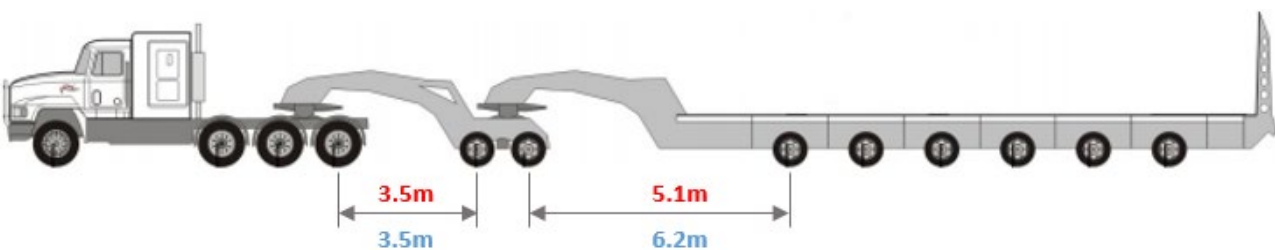

Prime mover to dolly axle spacing is compliant as no measurement adjustment is applicable.

Dolly to trailer axle spacing is non-compliant as measurement adjustment (1.1m) exceeds the maximum 300 mm allowed between dolly and trailer.

13 APPENDICES

| Appendix | Title |
|-------------------|---|
| Appendix 1 | Low Loader Overmass Period Permit Axle Spacing Ranges |
| Appendix 2 | Platform Trailer Relocation Period Permit Axle Spacing Ranges |
| Appendix 3 | Single Trip Permit Prime Mover Axle Spacing Range |

Appendix 1 – Low Loader Overmass Period Permit Axle Spacing Ranges

An OSV operating under the Low Loader Overmass Period Permit must comply with the minimum and maximum axle spacing requirements specified below:

| Axle Spacing | RAV Category | | | | | | | | | | | |
|--------------|--------------|-------------|-------------|-------------|-------------|-------------|-------------|-------------|-------------|-------------|-------------|-------------|
| | 1.1 | 1.2 | 1.3 | 1.4 | 1.5 | 1.6 | 1.7 | 2.1 | 2.2 | 2.3 | 3.1 | 3.2 |
| A | 2.9 – 5.8m | 2.9 – 5.8m | 2.9 – 5.8m | 2.9 – 5.8m | 2.9 – 5.8m | 2.9 – 5.8m | 2.9 – 5.8m | 2.9 – 5.8m | 2.9 – 5.8m | 2.9 – 5.8m | 2.9 – 5.8m | 2.9 – 5.8m |
| B | - | 1.2 – 1.8m | 1.2 – 1.8m | 1.2 – 1.8m | 1.2 – 1.8m | 1.2 – 1.8m | 1.2 – 1.8m | 1.2 – 1.8m | 1.2 – 1.8m | 1.2 – 1.8m | 1.2 – 1.8m | 1.2 – 1.8m |
| C | - | - | 1.5 – 4.3m | 1.8 – 4.3m | - | 1.5 – 4.3m | 1.8 – 4.3m | - | 1.5 – 4.3m | 1.8 – 4.3m | 1.7 – 4.3m | 1.7 – 4.3m |
| D | - | - | - | 1.2 – 1.8m | - | - | 1.2 – 1.8m | - | - | 1.2 – 1.8m | 1.1 – 1.8m | 1.1 – 1.8m |
| E | - | - | - | - | - | - | - | - | - | - | 1.1 – 1.8m | 1.1 – 1.8m |
| F | 6.0 – 17.8m | 6.0 – 17.8m | 6.0 – 17.8m | 6.0 – 17.8m | 6.0 – 17.8m | 6.0 – 17.8m | 6.0 – 17.8m | 6.0 – 17.8m | 6.0 – 17.8m | 6.0 – 17.8m | 6.0 – 17.8m | 6.0 – 17.8m |
| G | 1.2 – 1.85m | 1.2 – 1.85m | 1.2 – 1.85m | 1.2 – 1.85m | 1.2 – 1.81m | 1.2 – 1.81m | 1.2 – 1.81m | 1.2 – 1.81m | 1.2 – 1.81m | 1.2 – 1.81m | 1.2 – 1.81m | 1.2 – 1.81m |
| H | 1.2 – 1.85m | 1.2 – 1.85m | 1.2 – 1.85m | 1.2 – 1.85m | 2.3 – 2.8m | 2.3 – 2.8m | 2.3 – 2.8m | 1.2 – 1.81m | 1.2 – 1.81m | 1.2 – 1.81m | 1.2 – 1.81m | 2.3 – 2.8m |
| I | - | - | - | - | 1.2 – 1.81m | 1.2 – 1.81m | 1.2 – 1.81m | 1.2 – 1.81m | 1.2 – 1.81m | 1.2 – 1.81m | 1.2 – 1.81m | 1.2 – 1.81m |

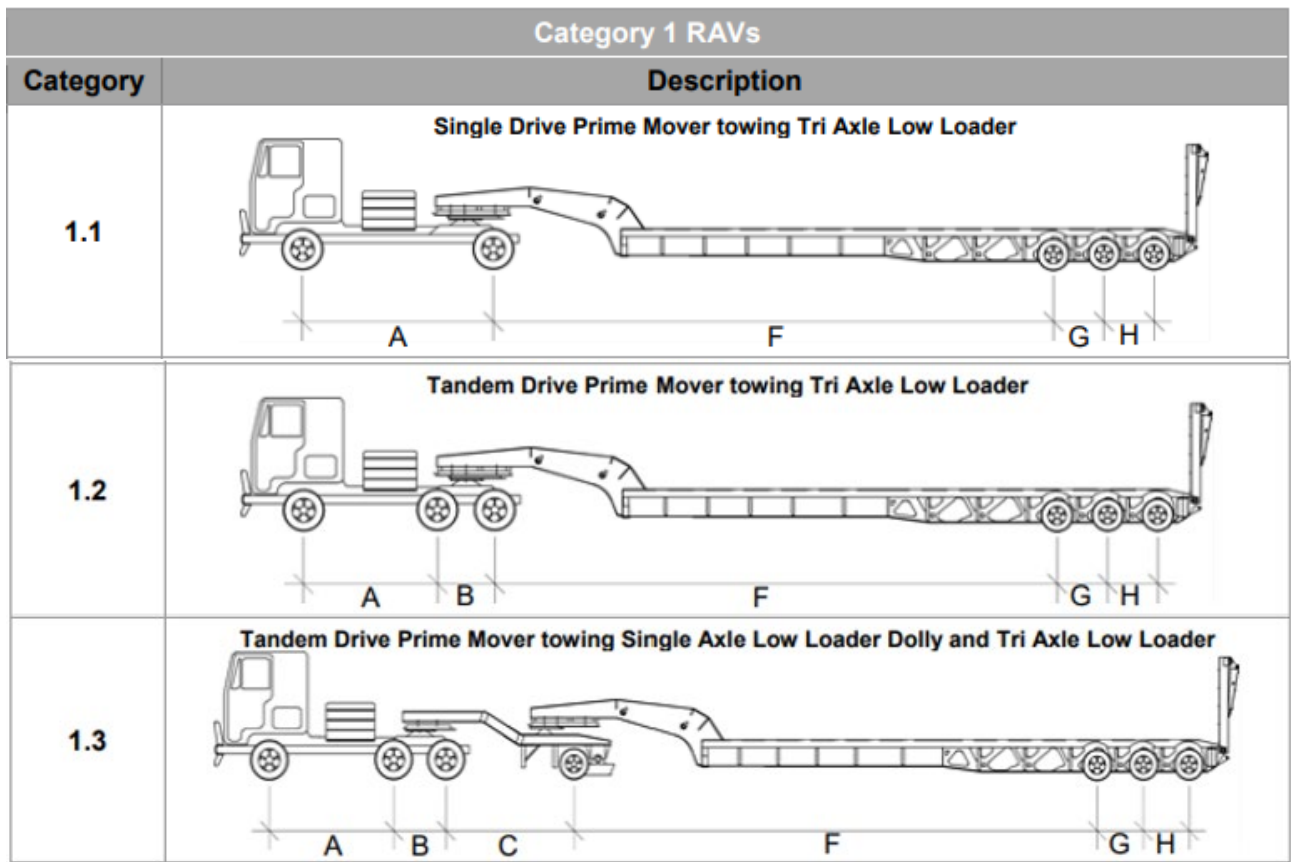

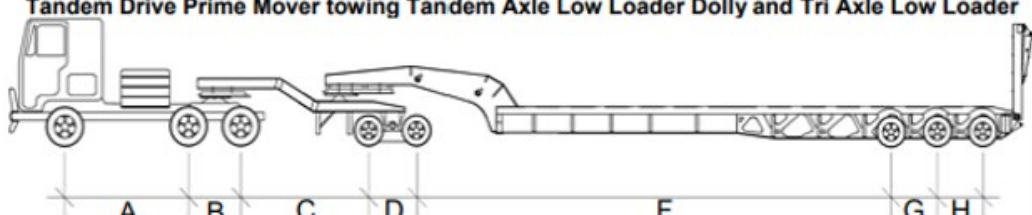
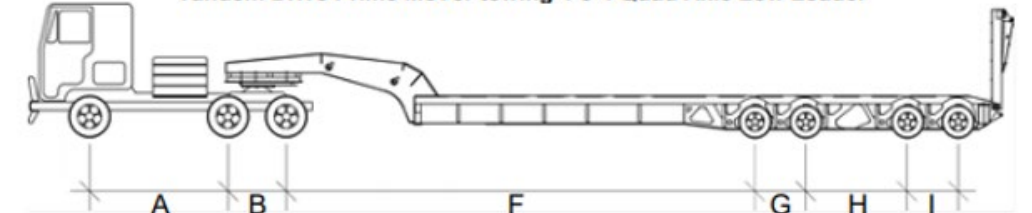
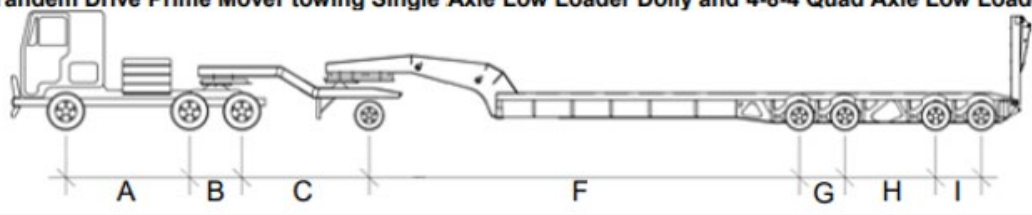
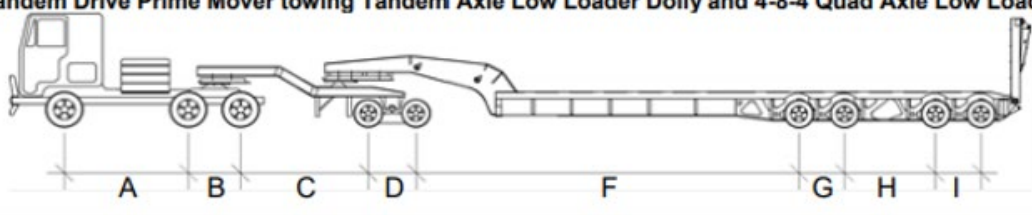
| | |
|-----|---|
| 1.4 | <p>Tandem Drive Prime Mover towing Tandem Axle Low Loader Dolly and Tri Axle Low Loader</p>  |
| 1.5 | <p>Tandem Drive Prime Mover towing 4-8-4 Quad Axle Low Loader</p>  |
| 1.6 | <p>Tandem Drive Prime Mover towing Single Axle Low Loader Dolly and 4-8-4 Quad Axle Low Loader</p>  |
| 1.7 | <p>Tandem Drive Prime Mover towing Tandem Axle Low Loader Dolly and 4-8-4 Quad Axle Low Loader</p>  |

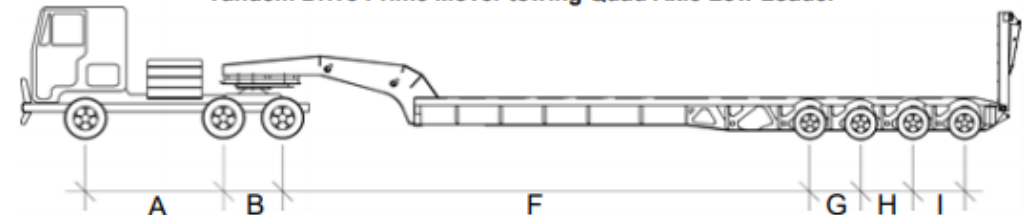
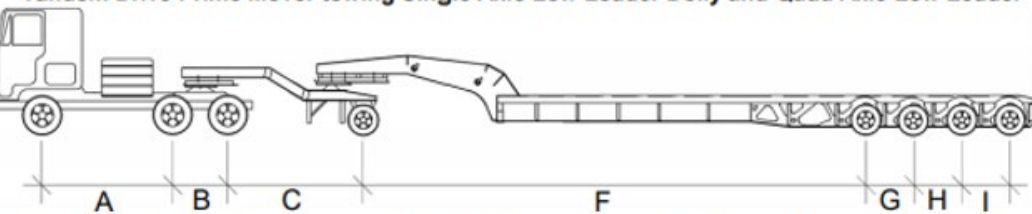
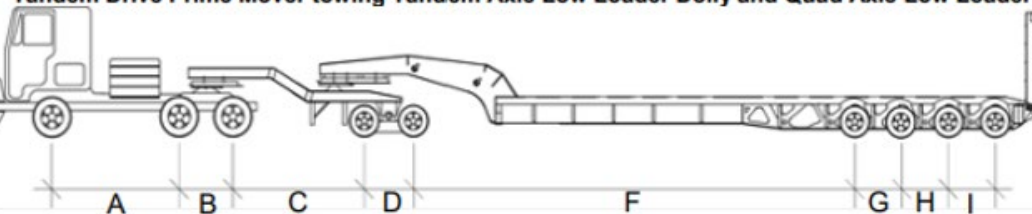
| Category 2 RAVs | |
|-----------------|--|
| Category | Description |
| 2.1 | <p>Tandem Drive Prime Mover towing Quad Axle Low Loader</p>  |
| 2.2 | <p>Tandem Drive Prime Mover towing Single Axle Low Loader Dolly and Quad Axle Low Loader</p>  |
| 2.3 | <p>Tandem Drive Prime Mover towing Tandem Axle Low Loader Dolly and Quad Axle Low Loader</p>  |

| Category 3 RAVs | |
|-----------------|---|
| Category | Description |
| 3.1 | <p>Tandem Drive Prime Mover towing Tri Axle Low Loader Dolly and Quad Axle Low Loader</p> |
| 3.2 | <p>Tandem Drive Prime Mover towing Tri Axle Low Loader Dolly and 4-8-4 Quad Axle Low Loader</p> |

Appendix 2 – Platform Trailer Relocation Period Permit Axle Spacing Ranges

An OSV operating under the Platform Trailer Relocation Period Permit must comply with the minimum and maximum axle spacing requirements specified below:

Single steer Tandem drive Prime Mover + 6 to 13 Axle Platform Trailer

| | | | | | | | | | |
|------|------|------|---|-------|-------|---|-------|-------|---|
| | ② | ④ | ④ | | ⑧ | ⑧ | | ⑧ | ⑧ |
| Min. | 2.9m | 1.2m | | 5.0m | 1.80m | | | 1.80m | |
| Max. | 5.8m | 1.8m | | 12.0m | 1.85m | | | 1.85m | |

Single steer Tandem drive Prime Mover with Dolly + 6 to 13 Axle Platform Trailer

| | | | | | | | | | | | |
|------|------|------|------|------|-------|--|-------|---|-------|-------|---|
| | ② | ④ | ④ | ④ | ④ | | ⑧ | ⑧ | | ⑧ | ⑧ |
| Min. | 2.9m | 1.2m | 2.5m | 1.2m | 5.0m | | 1.80m | | | 1.80m | |
| Max. | 5.8m | 1.8m | 4.0m | 1.8m | 12.0m | | 1.85m | | | 1.85m | |

Single steer Tri drive Prime Mover + 6 to 13 Axle Platform Trailer

| | | | | | | | | | | |
|------|------|------|------|-------|--|-------|---|-------|-------|---|
| | ② | ④ | ④ | ④ | | ⑧ | ⑧ | | ⑧ | ⑧ |
| Min. | 2.9m | 1.2m | 1.2m | 5.0m | | 1.80m | | | 1.80m | |
| Max. | 5.8m | 1.8m | 1.8m | 12.0m | | 1.85m | | | 1.85m | |

Single steer Tri drive Prime Mover with Dolly + 6 to 13 Axle Platform Trailer

| | | | | | | | | | | | | |
|------|------|------|------|------|------|-------|--|-------|---|-------|-------|---|
| | ② | ④ | ④ | ④ | ④ | ④ | | ⑧ | ⑧ | | ⑧ | ⑧ |
| Min. | 2.9m | 1.2m | 1.2m | 3.0m | 1.2m | 5.0m | | 1.80m | | | 1.80m | |
| Max. | 5.8m | 1.8m | 1.8m | 5.0m | 1.8m | 12.0m | | 1.85m | | | 1.85m | |

Example of how to measure axle spacing's:

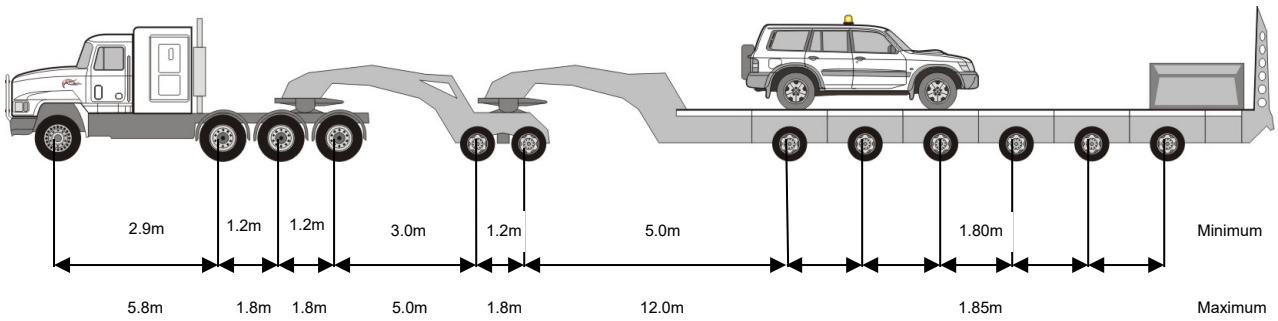

Appendix 3 – Single Trip Permit Prime Mover Axle Spacing Range

Where an alternate prime mover is being used under a Single Trip Permit (refer section 1.2.1 Single Trip Oversize Vehicle – Standard Operating Conditions), the alternate Prime Mover must:

- (a) Have the same axle configuration as the original vehicle; and
- (b) The alternate prime mover must have an axle spacing between 2.9 and 5.8 metres, measured from the centre of the front most axle to the centre of the front most drive axle.